

Prime Rating Range	
	KDG0500P1
	50Hz
kVA	500



### The Kohler Advantage

- One-stop solution for the generating system and accessories
- Manufactured in India with global expertise
- Compact design with ease of maintenance
- Best in class block loading capacity
- Flexible & creative customized solutions to meet customer needs
- Fast response time
- Two-years or 3000 hours as per standard warranty terms from date of initial startup

### Special Features

- Full authority electronic engine with superior energy efficiency and fuel economy
- Integral vibration isolation eliminates the need for under-unit vibration spring isolators
- Advanced Digital Controller (ADC) with 3 auto crank cycles
- Alternator features:
  - Alternator meets Indian and relevant section of other international standards
  - Self-ventilated and dripproof of IP23 construction
  - Superior voltage waveform by 2/3 pitch wound stator
  - Sustained short circuit current of up to 300% of the rated current for 3 seconds

### Standard Features

- Engine coupled, skid mounted alternator
- Single - bearing alternator with insulation Class H
- Unit mounted radiator with 50°C ambient temperature
- Base frame mounted fuel tank with minimum 8 hrs running capacity
- Dry type air filter with restriction indicator
- DG circuit breaker
- Electric start with battery
- Fuel water separator
- Conveniently located fuel level indicator
- Exhaust tail pipe as standard scope of supply
- Weather proof enclosure to withstand harsh climate
- All routine service points on one side of canopy
- Four point bottom lifting

### Conformance Standards

- ISO 3046
- BS 5514
- ISO 8528
- IS 4722
- IEC 34
- BS 5000 (Part 99)
- IS: 13364 (Part 1&2)

### Generator Set Ratings

Genset	Engine	Alternator	Voltage	Phase	Hz	Prime Rating		Amps
						kWe	kVA	
KDG0500P1	TAD1651GE	G1R355SE	415	3	50	400	500	695.6

PRIME POWER RATINGS: Prime power ratings apply to installations where utility power is unavailable or unreliable. At varying load, the number of generator set operating hours is unlimited. A 10% overload capacity is available for one hour in twelve. Ratings are in accordance with ISO-8528/1, overload power in accordance with ISO-3046/1 and BS 5514. For limited running time and base load ratings, consult the factory. Obtain the technical information bulletin (TIB-101) on ratings guidelines for the complete ratings definitions.

## Engine Specifications

Specifications	500 kVA
Engine : model, type	TAD1651GE, TCIC
No. of cylinders	6
Cylinder arrangement	Inline
Displacement, L (cu. in.)	16.12 (984)
Bore and stroke, mm (in.)	144 x 165 (5.67 x 6.50)
Compression ratio	16.5:1
Governor type	EMS 2.2
Governor Class	Class A1
Frequency regulation, steady state	ISO 8528 G3
Air cleaner type, Qty	Dry, 1
Unit-mounted radiator ambient temperature °C (°F)	50 (122)
Max. power kWm (BHP) @ rated speed (rpm)	441 (600) @ 1500
<b>Diesel Fuel Consumption</b>	
100% Load (Lph)	101.3
75% Load (Lph)	75.1
<b>Lube Oil Consumption</b>	
100% load (Lph)	0.1
<b>Fuel System</b>	
Fuel prime pump	Mechanical
Fuel filter : Type, Qty	Primary / Secondary, 2
Recommended fuel	HSD-ASTM D2
Fuel tank capacity, L	660
Fuel filter change period	Initial - 100 hrs / 3 months, Subsequent 500 hrs / 12 months, whichever is earlier
<b>Lubrication System</b>	
System type	Forced Lubrication
Lube oil type	Kohler Oil
Oil pan capacity with filter, L	48
Oil filter: Quantity, Type	3, Cartridge
Oil and oil filter change period	Initial - 100 hrs / 3 months, Subsequent 500 hrs / 12 months, whichever is earlier
<b>Exhaust System</b>	
Maximum allowable back pressure, KPa (in.Hg)	10 (2.9)
Exhaust outlet size at engine hookup, mm (in)	110 (4.33)
Silencer Type, Quantity	Residential, 1
Exhaust temperature at rated kW, dry exhaust, °C (°F)	500 (932)
<b>Cooling System</b>	
Ambient temperature, °C (°F)	50 (122)
Coolant capacity including engine, L (gal)	60 (15.9)
Water pump type	Centrifugal
Fan diameter, including blades, mm (in.)	890 (35)
<b>Engine Electrical System</b>	
Starter Motor rated voltage VDC	24 V
Battery charging alternator	24 V, 150 Amp
Ground (negative/positive)	Negative
Battery type-	Flooded type, Maintenance free
Amp/hour	105
Quantity	2
Battery voltage, VDC	24

## Alternator Specifications

Specifications	500 kVA
Type	4 Pole
Exciter type	Brushless
Voltage regulator	AVR-UVR-7
Insulation - Material - Temperature rise, Prime	Class H 125°C
Bearing: Quantity, Type	1, Sealed
Coupling	Flexible disk
Voltage regulation	+/-1%
Excitation	Self excitation
Frequency, Fixed, Hz	50
Short circuit ratio	0.426
Full load current - 3 Phase	695.6
Prime at 125° C, kVA	500

## Advanced Digital Controller (ADC3503)

### Standard Features

- Master switch: Control On/Off
- Event Log
- Remote two-wire start/stop capability
- One-source responsibility for generating system & accessories
- Automatic start with programmed cranking cycle
- Field software upgrade possibility
- Operating temperature: -20°C to 70°C (-4°F to 158°F)
- Storage temperature: -60°C to 70°C (-76°F to 158°F)
- Humidity: 0-95% condensing
- Control Panel
  - Alternator to control panel connection with copper cable only
  - MCCB/MCB details : with short circuit and overload protection
  - Inbuilt AMF controller
  - Output Aluminium cable size : (Sq.mm x run) : 3 Phase :

500 kVA	
300 x 2	185 x 3



### Optional Features

- Microprocessor based AMF control panel
- Synchronizing controller
- GPRS based generator monitoring system
- Air Circuit Breaker

## Controller Information

LCD Display	LCD Display Faults	Display Warnings	Optional Accessories	Power Requirements
Runtime hours	High engine temperature	Low battery voltage	Battery charger 24 V	8 V to 35 V continuous
Engine speed	Low oil pressure	High battery voltage	Mains sensing relay inbuilt	85 mA @ 12 VDC
Power factor KVA	Overspeed / Underspeed	Low fuel level	Earth leakage protection	96 mA @ 24 VDC
Current	Over and under voltage	Maintenance Alarm (water in fuel)	VAF meter (Multifunction)	
Voltage	Over and under frequency		kW-hr display	
Frequency	E-stop			
Engine temperature	Auxiliary fault			
Engine oil pressure	Low fuel level			
Battery voltage	Over load current			
Kilowatt & kVA	Phase reversal			
Fuel level (digital I/P)				

## Regulatory Compliance

Specifications	500 kVA
As per ISO 8178-5 mode cycle (Engine emission)	CPCB-II compliant
Noise level measured at 1 meter distance	< 75 dB (A)

## Dimensions and weight

Specifications	500 kVA
Overall Size, L x W x H (mm)	5560 x 1640 x 2483
Overall Size with silencer, L x W x HT (mm)	5560 x 1640 x 3433
Dry, max (kg)	6000

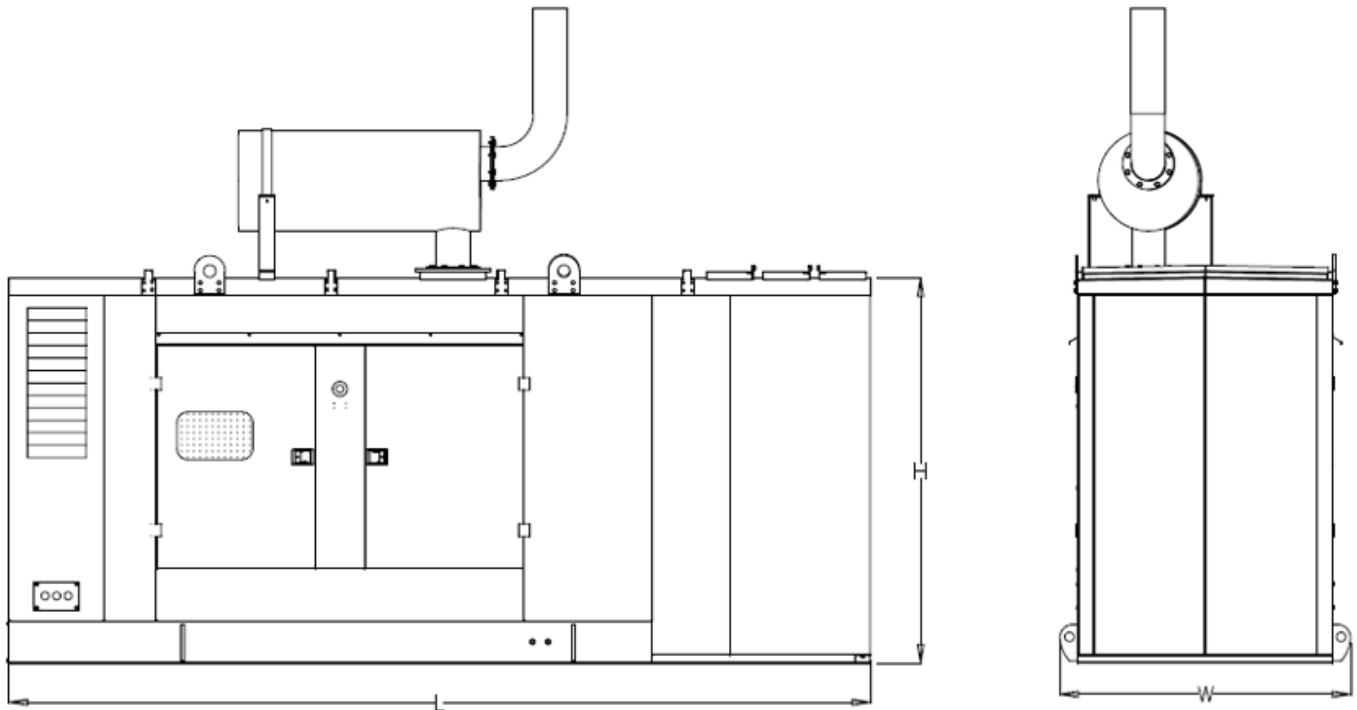

NOTE : Drawing provided is for reference only and should not be used for planning installation. Please contact the Company for latest updated details.

All the data is as per respective manufacturers' specification.  
Please refer O & M manual for maintenance and preservation guidelines.

KOHLER reserves the right to change the design or specifications without notice and without any obligation or liability whatsoever.

**KOHLER**<sup>®</sup>  
IN POWER. SINCE 1920.

Corporate Office :  
Kohler Power India Pvt. Ltd.,  
701 & 702, 7th Floor, Pentagon Tower P5,  
Magarpatta City, Hadapsar, Pune - 411013,  
Maharashtra, India.

Regional Offices :  
Pune : +91 20 6649 7101 | New Delhi : +91 11 4102 2919  
Kolkata : +91 33 4063 3512 | Bangalore : +91 80 4286 7000

Factory :  
Kohler Power India Pvt. Ltd.,  
(Formerly: Lombardini India Pvt. Ltd.),  
J-2/1, MIDC Chikalthana, CIDCO,  
Aurangabad - 431210, Maharashtra, India.

Authorised Channel Partner:

**ISO 9001**  
**KOHLER**<sup>®</sup>  
IN POWER. SINCE 1920.  
NATIONALLY REGISTERED

Printed in India

© 2019 by Kohler Co.

All rights reserved. Use of this material is strictly prohibited  
without written permission from Kohler Co.

kohlerpower.in / 1800 266 0600 / kpi.info@kohler.com / +91 95 2777 7779