

# Model: 1600REOZM

## KOHLER Power Systems

380-480 V

4-Cycle Diesel



**Tier 1 EPA-Certified for Stationary Emergency Applications**

### Ratings Range

		60 Hz	50 Hz
Standby:	kW	1625-1630	1380-1480
	kVA	2031-2038	1725-1850
Prime:	kW	1475-1480	1280-1368
	kVA	1844-1850	1600-1710
DCC :	kW	1475-1480	1280-1368
	kVA	1844-1850	1600-1710

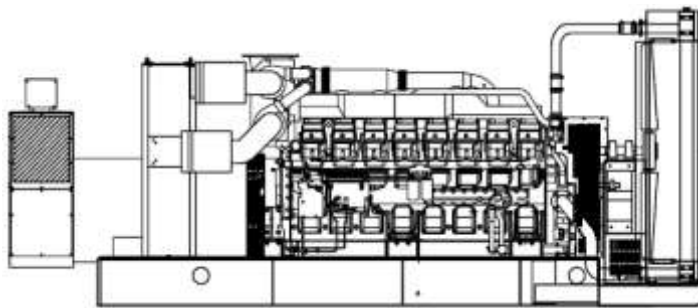

### Standard Features

- Kohler Co. provides one-source responsibility for the generating system and accessories.
- The generator set and its components are prototype-tested, factory-built, and production-tested.
- The 60 Hz generator set offers a UL 2200 listing.
- The generator set complies with ISO 8528-5, Class G3 requirements for transient performance.
- The generator set accepts rated load in one step.
- The generator set meets NFPA 110, Level 1, when equipped with the necessary accessories and installed per NFPA standards.
- A standard one-year limited warranty covers all systems and components. Two-, five-, and ten-year extended warranties are also available.
- Alternator features:
  - The pilot-excited, permanent magnet (PM) alternator provides superior short-circuit capability
  - The brushless, rotating-field generator has broad range reconnectability.
- Other features:
  - Kohler designed controllers for guaranteed system integration and remote communication. See Controllers on page 3
  - The low coolant level shutdown prevents overheating (standard on radiator models only).
  - An electronic, isochronous governor delivers precise frequency regulation.
  - Multiple circuit breaker configurations.

Alternator	Voltage	Ph	Hz	150°C Rise Standby Rating		125°C Rise Prime Rating		125°C Rise DCC Rating	
				kW/kVA	Amps	kW/kVA	Amps	kW/kVA	Amps
7M4052	220/380	3	50	1480/1850	2811	1368/1710	2598	1368/1710	2598
	230/400	3	50	1448/1810	2613	1320/1650	2382	1320/1650	2382
	240/416	3	50	1380/1725	2394	1280/1600	2220	1280/1600	2220
	277/480	3	60	1630/2038	2451	1480/1850	2225	1480/1850	2225
7M4174	220/380	3	60	1625/2031	3086	1475/1844	2801	1475/1844	2801

**RATINGS:** All three-phase units are rated at 0.8 power factor. Standby Ratings: The standby rating is applicable to varying loads for the duration of a power outage. There is no overload capability for this rating. Prime Power Ratings: At varying load, the number of generator set operating hours is unlimited. A 10% overload capacity is available for one hour in twelve. Ratings are in accordance with ISO-8528-1 and ISO-3046-1. For limited running time and continuous ratings, consult the factory. DCC : Data Center Continuous Power ratings apply to Data Center installations where a reliable utility power is available and comply with Uptime institute Tier III and IV requirements. At constant or varying load, the number of generator set operating hours is unlimited. Average load: ≤ 100%. For limited running time and base load ratings, consult the factory. Obtain technical information bulletin (TIB-101) for ratings guidelines, complete ratings definitions, and site condition derates. The generator set manufacturer reserves the right to change the design or specifications without notice and without any obligation or liability whatsoever.

# Alternator Specifications

Specifications	Generator
Type	4-Pole, Rotating-Field
Exciter type	Brushless, Permanent-
	Magnet Pilot Exciter
Voltage regulator	Solid State, Volts/Hz
Insulation:	NEMA MG1
Material . . . . .	Class H, Synthetic, Nonhygroscopic
Temperature rise . . . . .	125°C Prime, 150°C Standby
Bearing: quantity, type	1, Sealed
Coupling	Flexible Disc
Amortisseur windings	Full
Rotor balancing	125% 60 Hz, 150% 50Hz
Voltage regulation, no-load to full-load (with <0.5% drift due to temp Variation)	3-Phase Sensing, ±0.25%
One-step load acceptance	100% of Rating
Unbalanced load capability	100% of Rated Standby Current
Peak motor starting kVA:	(35% dip for voltages below)
480 V, 380 V    7M4052 (4 bus bar) . .	5500 (60Hz), 4000 (50Hz)
380 V            7M4174 (4 bus bar) . .	4200 (60Hz)

- NEMA MG1, IEEE, and ANSI standards compliance for temperature rise and motor starting.
- Sustained short-circuit current of up to 300% of the rated current for up to 10 seconds.
- Sustained short-circuit current enabling downstream circuit breakers to trip without collapsing the generator field.
- Self-ventilated and drip-proof construction.
- Superior voltage waveform from two-thirds pitch windings and skewed stator.
- Digital solid-state, volts-per-hertz voltage regulator with ±0.25% no-load to full-load regulation.
- Brushless alternator with brushless pilot exciter for excellent load response.

## Application Data

### Engine

Engine Specifications	60 Hz	50 Hz
Engine model	S16R-Y1 PTA-2	S16R-Y1 PTA-4
Engine type	4-Cycle,  Turbocharged, Intercooled	
Cylinder arrangement	16-V	
Displacement, L (cu. in.)	65.4 (3989)	
Bore and stroke, mm (in.)	170 x 180 (6.69 x 7.09)	
Compression ratio	15.0:1	
Piston speed, m/min. (ft./min.)	648 (2126)	540 (1772)
Main bearings: quantity, type	-	
Rated rpm	1800	1500
Max. power at rated rpm, kWm (BHP)	1750 (2346)	1701 (2280)
Cylinder head material	Cast Iron	
Crankshaft material	Forged Steel	
Governor: type, make/model	Electronic, Woodward PROACT II	
Frequency regulation, no-load to full-load	Isochronous	
Frequency regulation, steady state	±0.25%	
Frequency	Fixed	
Air cleaner type, all models	Dry	

### Exhaust

Exhaust System	60 Hz	50 Hz
Exhaust manifold type	Dry	
Exhaust flow at rated kW, m <sup>3</sup> /min. (cfm)	404 (14265)	385 (13594)
Exhaust temperature at rated kW, dry exhaust, °C (°F)	520 (968)	519 (966)
Maximum allowable back pressure, kPa (in. Hg)	5.9 (1.7)	
Exhaust outlet size at engine hookup, mm (in.)	See ADV drawing	

### Engine Electrical

Engine Electrical System	60 Hz	50 Hz
Battery charging alternator:		
Ground (negative/positive) . . . . .		Negative
Volts (DC) . . . . .		24
Ampere rating . . . . .		30
Starter motor rated voltage (DC)		Dual, 24
Battery, recommended cold cranking amps (CCA):		
Qty., CCA rating		4, 1000
Battery voltage (DC)		12

### Fuel

Fuel System	60 Hz	50 Hz
Fuel supply line, min. ID, mm (in.)		25 (1.0)
Fuel return line, min. ID, mm (in.)		19 (0.75)
Max. lift, engine-driven fuel pump, m (ft.)		1 (3)
Max. fuel flow, Lph (gph)	560 (148)	510 (135)
Max. fuel pump restriction, kPa (in. Hg)		10 (3.0)
Fuel filter: quantity, type		4, Secondary
Recommended fuel		#2 Diesel

### Lubrication

Lubricating System	60 Hz	50 Hz
Type		Full Pressure
Oil pan capacity, L (qt.)		200 (211)
Oil pan capacity with filter, L (qt.)		230 (243)
Oil filter: quantity, type		4, Cartridge
Oil Cooler		Water-Cooled

# Application Data

# Controllers

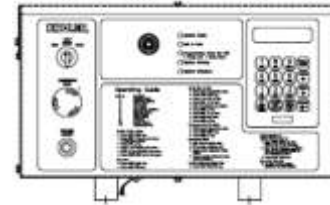

## Cooling

Radiator System	60 Hz	50 Hz
Ambient temperature	40 (104)	
Engine jacket water capacity, L (gal.)	170 (44.9)	
Radiator system capacity, including engine, L (gal.)	250 (66.1)	315 (83.3)
Engine jacket water flow, Lpm (gpm)	1850 (489)	1650 (436)
Heat rejected to cooling water at rated kW, dry exhaust, kW (Btu/min.)	1135 (64532)	1063 (60452)
Water pump type	Centrifugal	
Fan diameter, including blades, mm (in.)	1800 (70.9)	
Fan, kWm (HP)	45 (60)	45 (60)
Max. restriction of cooling air, intake and discharge side of radiator, kPa (in. H <sub>2</sub> O)	0.125 (0.5)	

### Decision-Maker® 550 Controller

Audiovisual annunciation with NFPA 110 Level 1 capability. Programmable microprocessor logic and digital display features. Generator safeguard circuit protection. 12- or 24-volt engine electrical system capability. Remote start, remote annunciation, and remote communication options. Refer to G6-46 for additional controller features and accessories.

## Operation Requirements

Air Requirements	60 Hz	50 Hz
Radiator-cooled cooling air, m <sup>3</sup> /min. (scfm) ~	2435 (86000)	2311 (81600)
Combustion air, m <sup>3</sup> /min. (cfm)	155 (5473)	146 (5155)
Heat rejected to ambient air:		
Engine, kW (Btu/min.) . . . . .	135 (7744)	127 (7254)
Generator, kW (Btu/min.) . . . . .	82 (4663)	
~ Air density = 1.20 kg/m <sup>3</sup> (0.075 lbm/ft <sup>3</sup> )		

Fuel Consumption	60 Hz	50 Hz
<b>Diesel, Lph (gph) at % load</b>	<b>Standby Rating</b>	
100%	430 (113.7)	383 (101.4)
75%	321 (84.9)	283 (74.8)
50%	224 (59.1)	195 (51.5)
25%	127 (33.6)	109 (28.8)
<b>Diesel, Lph (gph) at % load</b>	<b>Prime Rating</b>	
100%	389 (102.8)	344 (91.1)
75%	295 (77.9)	258 (68.3)
50%	209 (55.2)	180 (47.7)
25%	124 (32.8)	105 (27.7)

## Standard Features and Accessories

### Additional Standard Features

- Alternator Protection (standard with Decision-Maker® 550)
- Electronic, Isochronous Governor
- Oil Drain Extension
- Operation and Installation Literature
- Pilot-Excited, Permanent Magnet Generator (PMG)

### Accessories

#### Open Unit

- Exhaust Silencer, Hospital
- Exhaust Silencer, Critical
- Flexible Exhaust Connector, Stainless Steel

#### Cooling System

- Block Heater  
[recommended for ambient temperatures below 20°C (68°F)]
- Radiator Duct Flange

#### Fuel System

- Flexible Fuel Lines
- Fuel Pressure Gauge
- Fuel/Water Separator
- Subbase Fuel Tank with Day Tank

#### Electrical System

- Battery
- Battery Charger, Equalize/Float Type
- Battery Heater
- Battery Rack and Cables

#### Engine and Generator

- Air Cleaner, Heavy Duty
- Air Cleaner Restriction Indicator
- Bus Bar Kits (standard on 7M generators, 380-600 volt only)
- Crankcase Emissions Canister
- Engine Fluids (oil and coolant) Added
- Generator Strip Heater
- Line Circuit Breaker (NEMA type 1 enclosure)
- Line Circuit Breaker with Shunt Trip (NEMA type 1 enclosure)
- Oil Temperature Gauge
- Optional Generators
- Rated Power Factor Testing

#### Paralleling System

- Load-Sharing Module
- Voltage Adjustment Control (manual)

### Maintenance and Literature

- General Maintenance Literature Kit
- Maintenance Kit (includes air, oil, and fuel filters)
- NFPA 110 Literature
- Overhaul Literature Kit
- Production Literature Kit

### Controller

- Common Failure Relay Kit
- Communications Products and PC Software  
(Decision-Maker® 550 only)
- Customer Connection Kit
- Dry Contact Kit (isolated alarm)
- Prime Power Switch (Decision-Maker® 550 only)
- Remote Annunciator Panel
- Remote Audiovisual Alarm Panel
- Remote Emergency Stop Kit
- Remote Mounting Cable
- Run Relay Kit

### Miscellaneous Accessories

- \_\_\_\_\_
- \_\_\_\_\_
- \_\_\_\_\_
- \_\_\_\_\_
- \_\_\_\_\_
- \_\_\_\_\_
- \_\_\_\_\_

### Dimensions and Weights

Overall Size, L x W x H, mm (in.): 5768 x 2212 X 2505  
 (227.1 x 87.1 X 98.6)  
 Weight (radiator model), wet, max., kg (lb.): 13300 (29296)

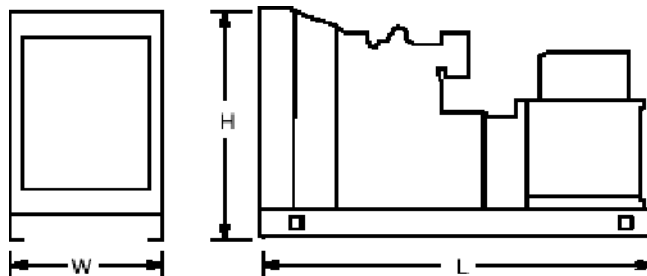

NOTE: This drawing is provided for reference only and should not be used for planning installation. Contact your local distributor for more detailed information.

**DISTRIBUTED BY:**